

*Crap & Win!*  
**iPad Pro**

Check out our contest!  
suzuka.com.my/promotion | T&C Apply



# KASTONE®

STONE VENEER COLLECTIONS

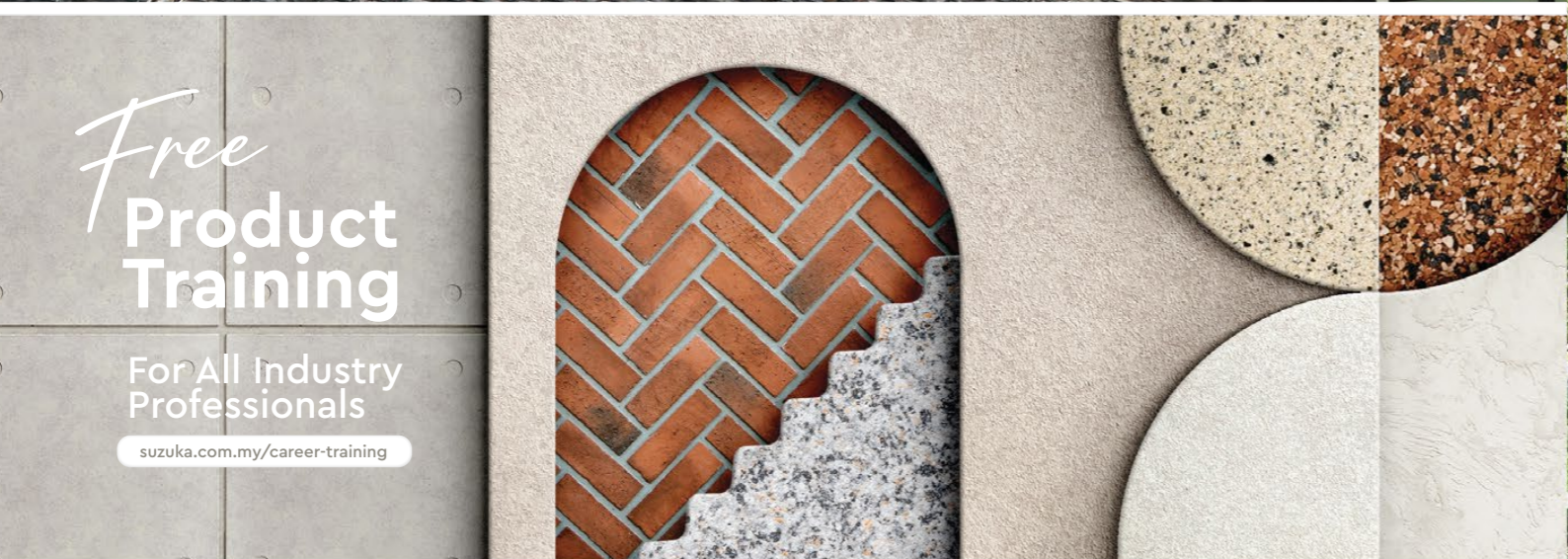

*Free*  
**Product Training**

For All Industry Professionals

[suzuka.com.my/career-training](http://suzuka.com.my/career-training)



**suzuka.com.my**

**suzuka.group** **+6012-258 7388**



All images included in this catalog are for visual reference only. Actual product may have a slight color difference due to variations in printing processes or digital viewing settings. We suggest you examine actual product samples before ordering.



KASTONE STONE-E25.2-2606

# KASTONE®

## BRICK VENEER COLLECTIONS

KASTONE® products range from classic brick styles to timeless stone designs. Our brick and stone veneer collections showcase a wide variety of colours, shapes, and textures, catering to any interior or exterior space.

KASTONE® veneers are authentic in appearance and feel, as each piece is uniquely crafted to mirror natural stones and bricks. Comprised only of premium raw materials, our veneers' lightweight and durable nature streamlines the installation process while minimizing costs and maintenance work.

Corner Brick



Flat Brick



WALL FINISH PROFESSIONALS



**SUZUKA® Malaysia** belongs to the **SUZUKA® Group**, which holds manufacturing companies in Taiwan, Malaysia, and Thailand. As one of South East Asia's leading manufacturers in decorative building materials, SUZUKA® Malaysia's expertise in wall finishes dates back to its origins in the town of Suzuka, Japan, after World War II. Specializing in a wide range of stone veneers, waterproofing materials, and textured coatings, we offer durable products that are suitable for decorating and protecting both the interiors and exteriors of your homes and commercial buildings.

Not only do our products cater to buildings of various aesthetics and designs, but they also exceed international quality and safety standards. Armed with protection against UV damage, water seepage, dust, dirt and stains, we lower potential maintenance costs in the future. In addition to being an ISO 9001 certified company, we also carry a selection of SIRIM QAS certified products and a range of environmentally-friendly products certified by Singapore Green Label and SIRIM Eco Label.

Within the past decade, we've become an international supplier to number of regions, including Australia, Saudi Arabia, Thailand, Cambodia, Qatar, the United Arab Emirates, Bahrain, Indonesia, Singapore, and West Africa.

To experience why SUZUKA® products are trusted around the world, choose from our extensive range of coatings and artificial stone veneers.



DS-191

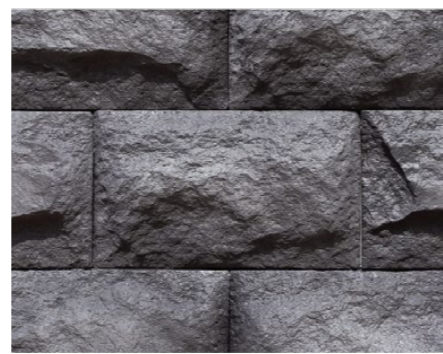

DS-192



WS-3001



WS-3002



WS-3003



WS-3004



WS-3005

## DS-19



Coverage (Per Box) : 3.7 ~ 4.2 sqf  
 Weight (Per Box) : 30 kg  
 Pieces (Per Box) : 3 pcs

\* Please allow a +/- 5% tolerance for stone size & colour

### Recommended Installation Layout

- Arrange the stones in a zig zag pattern.
- Arrange the colors/shades randomly and evenly (you may try laying the stones on the floor first).

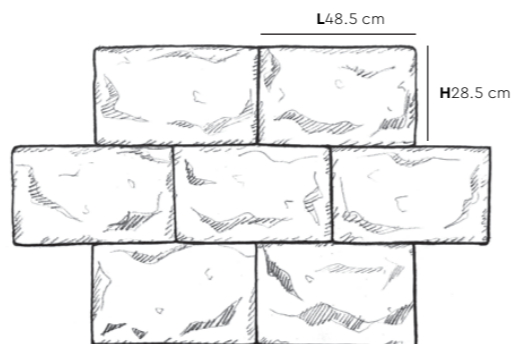

## WS-300



Coverage (Per Box) : 10.5 ~ 10.7 sqf  
 Weight (Per Box) : 23.5 kg  
 Pieces (Per Box) : 14 pcs

\* Please allow a +/- 5% tolerance for stone size & colour

### Recommended Installation Layout

- Arrange the stones in a zig zag pattern.
- Arrange the colors/shades randomly and evenly (you may try laying the stones on the floor first).

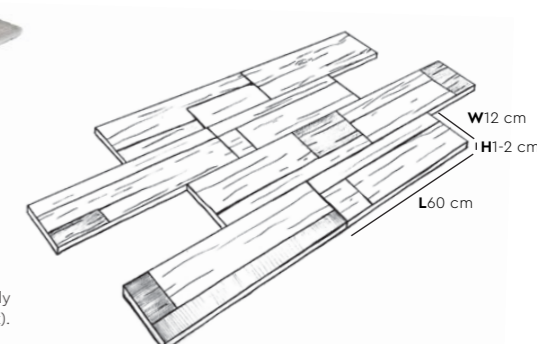



KST-1001



KST-1002



KST-1003A



KST-1004A



DS-401



DS-402

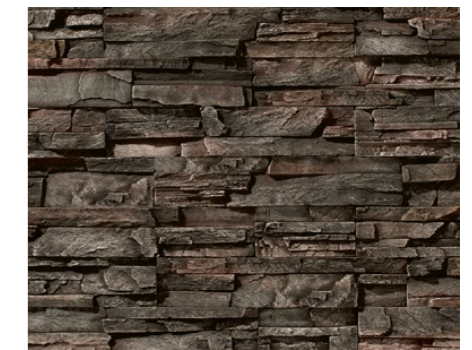

DS-403

# KST-100

Coverage (Per Box) : **7.6 ~ 7.8 sqf**  
 Weight (Per Box) : **20.2 kg**  
 Pieces (Per Box) : **6 pcs**

*\* Please allow a +/- 5% tolerance for stone size & colour*

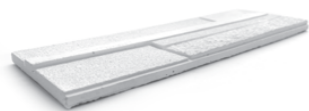

### Recommended Installation Layout

- Arrange the stones in a zig zag pattern.
- Arrange the colors/shades randomly and evenly (you may try laying the stones on the floor first).

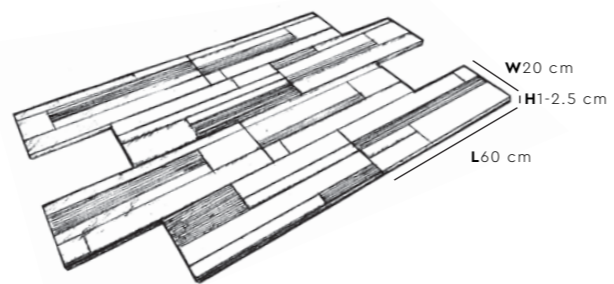

# DS-40

Flat Stone  
 Coverage (Per Box) : **6.9 ~ 7.6 sqf**  
 Weight (Per Box) : **26.8 kg**  
 Pieces (Per Box) : **14 pcs**

Corner Stone  
 5.1 ~ 5.3 f  
 15.4 kg  
 16 pcs

### Recommended Installation Layout

- Arrange the stones in a zig zag pattern.
- Arrange the colors/shades randomly and evenly (you may try laying the stones on the floor first).

*\* Please allow a +/- 5% tolerance for stone size & colour*

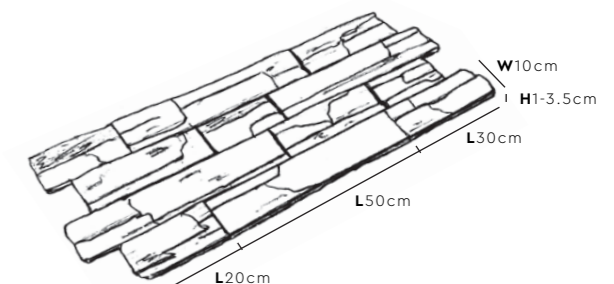
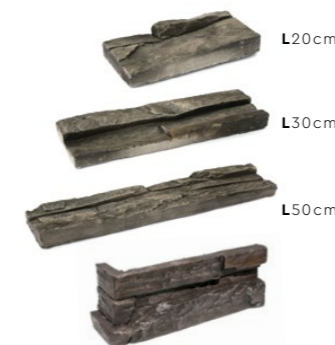



# DS-00

Flat Stone:  
 Coverage (Per Box) : **6.9 ~ 7.6 sqf**  
 Weight (Per Box) : **26.8 kg**  
 Pieces (Per Box) : **14 pcs**

Corner Stone:  
 Coverage (Per Box) : **5.1 ~ 5.3 f**  
 Weight (Per Box) : **15.4 kg**  
 Pieces (Per Box) : **16 pcs**

\* Please allow a +/- 5% tolerance for stone size & colour



DS-001



DS-002



DS-003



DS-004



DS-011



DS-013



DS-015



DS-016



DS-017



DS-018

# DS-01

Flat Stone  
 Coverage (Per Box) : **5.9 ~ 6.5 sqf**  
 Weight (Per Box) : **23.2 kg**  
 Pieces (Per Box) : **12 pcs**

Corner Stone  
 Coverage (Per Box) : **5.1 ~ 5.3 f**  
 Weight (Per Box) : **15.5 kg**  
 Pieces (Per Box) : **16 pcs**

## Recommended Installation Layout

- Arrange the stones in a zig zag pattern.
- Arrange the colors/shades randomly and evenly (you may try laying the stones on the floor first).

\* Please allow a +/- 5% tolerance for stone size & colour

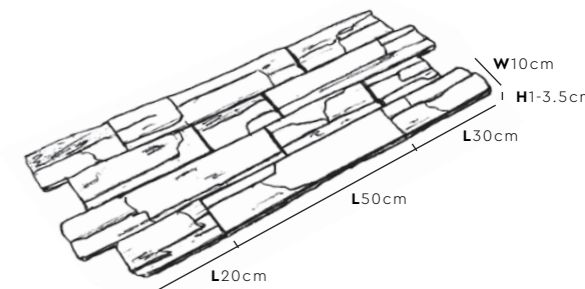



# DS-30

Flat Stone:

Coverage (Per Box) : **7.2 ~ 7.8 sqf**

Weight (Per Box) : **30.5 kg**

Pieces (Per Box) : **16 pcs**

Corner Stone:

Coverage (Per Box) : **6.1 ~ 6.3 f**

Weight (Per Box) : **23.3 kg**

Pieces (Per Box) : **16 pcs**

\* Please allow a +/- 5% tolerance for stone size & colour



DS-301



DS-302



DS-303



DS-304



DS-305



DS-306



## Recommended Installation Layout

- Arrange the stones in a zig zag pattern.
- Arrange the colors/shades randomly and evenly (you may try laying the stones on the floor first).

\* Please allow a +/- 5% tolerance for stone size & colour

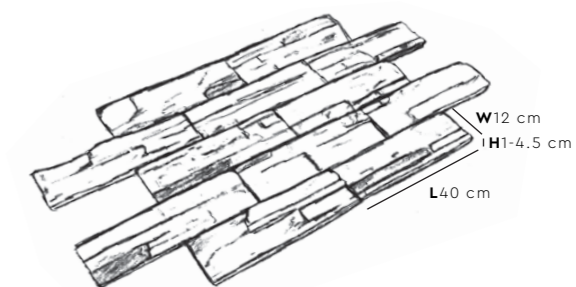



# DS-80

Flat Stone:  
 Coverage (Per Box) : **10.5 ~ 10.8 sqf**  
 Weight (Per Box) : **33.4 kg**  
 Pieces (Per Box) : **35 pcs**

Corner Stone:  
 Coverage (Per Box) : **7.5 ~ 7.8 f**  
 Weight (Per Box) : **28.6 kg**  
 Pieces (Per Box) : **40 pcs**



\* Please allow a +/- 5% tolerance for stone size & colour



DS-801



DS-802



DS-804



DS-805



DS-806



DS-807



DS-808



DS-809

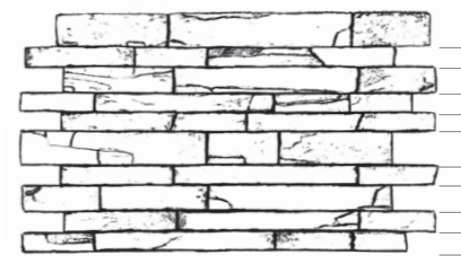

### Recommended Installation Layout

• Arrange stones randomly. • Stones may be trimmed to fit the required size. (you may try laying the stones on the floor first).

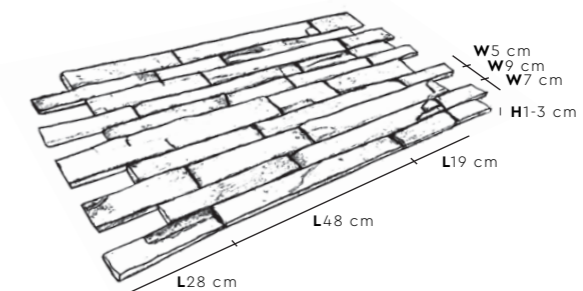

### SIZES

- A1 : 9.0 x 19.0 cm
- A2 : 9.0 x 28.0 cm
- A3 : 9.0 x 48.0 cm
- B1 : 7.0 x 19.0 cm
- B2 : 7.0 x 28.0 cm
- B2 : 7.0 x 48.0 cm
- C1 : 5.0 x 19.0 cm
- C2 : 5.0 x 28.0 cm
- C3 : 5.0 x 48.0 cm



DS-071



DS-072



DS-073



DS-074



DS-075

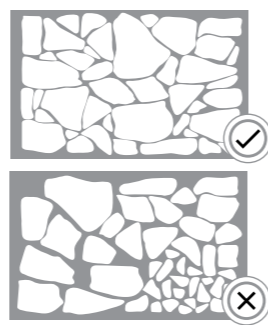

## DS-07

Flat Stone:  
 Coverage (Per Box) : **5.9 ~ 6.3 sqf**  
 Weight (Per Box) : **23.5 kg**  
 Pieces (Per Box) : **12 ~ 14 pcs**

Corner Stone:  
 Coverage (Per Box) : **5.9 ~ 6.1 f**  
 Weight (Per Box) : **27.8 kg**  
 Pieces (Per Box) : **7 ~ 8 pcs**

### Recommended Installation Layout

- Arrange stones randomly.
- Stones may be trimmed to fit the required size. (you may try laying the stones on the floor first).

\* Please allow a +/- 5% tolerance for stone size & colour.  
 \* The packing coverage and length for DS-07XX are inclusive of 1 cm groove lines  
 \* This product may take longer to deliver, please contact us to find out more.

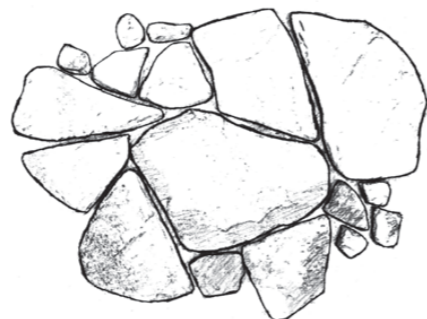

## DS-17

Flat Stone:  
 Coverage (Per Box) : **5.9 ~ 6.3 sqf**  
 Weight (Per Box) : **20.6 kg**  
 Pieces (Per Box) : **24 ~ 27 pcs**

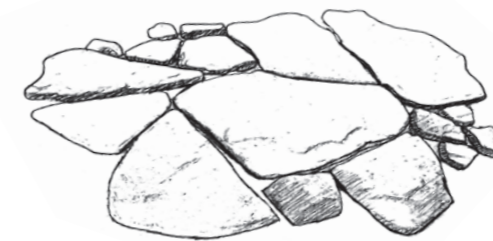

- \* Please allow a +/- 5% tolerance for stone size and colour
- \* The packing coverage and length for DS-17X are inclusive of 1.5 cm groove lines
- \* This product may take longer to deliver, please contact us to find out more.

### Recommended Installation Layout

- Arrange stones randomly.
- Stones may be cut to fit the required size. (you may try laying the stones on the floor first).



DS-171



DS-172



DS-041



DS-044



DS-045



DS-047



DS-031



DS-034

## DS-04

Flat Stone:  
Coverage (Per Box) : **7.0 ~ 7.4 sqf**  
Weight (Per Box) : **29.6 kg**  
Pieces (Per Box) : **17 ~ 21 pcs**

Corner Stone:  
Coverage (Per Box) : **5.9 ~ 6.1 f**  
Weight (Per Box) : **20.6 kg**  
Pieces (Per Box) : **8 pcs**

### Recommended Installation Layout

- Arrange stones randomly.
- Stones may be trimmed to fit the required size.  
(you may try laying the stones on the floor first).

\* Please allow a +/- 5% tolerance for stone size & colour  
\* This product may take longer to deliver, please contact us to find out more.



### SIZES

<b>A</b> : 4.7 x 4.7 cm	<b>I</b> : 14.5 x 24.5 cm	<b>Q</b> : 20.0 x 15.0 cm
<b>B</b> : 4.7 x 9.8 cm	<b>J</b> : 14.5 x 29.5 cm	<b>R</b> : 20.0 x 35.0 cm
<b>C</b> : 4.7 x 14.5 cm	<b>K</b> : 29.0 x 40.0 cm	<b>S</b> : 15.0 x 15.0 cm
<b>D</b> : 9.8 x 9.8 cm	<b>L</b> : 29.0 x 29.0 cm	<b>T</b> : 20.0 x 25.0 cm
<b>E</b> : 9.8 x 14.5 cm	<b>M</b> : 24.5 x 29.0 cm	<b>U</b> : 24.0 x 10.0 cm
<b>F</b> : 9.8 x 19.5 cm	<b>N</b> : 19.5 x 29.0 cm	<b>V</b> : 24.0 x 24.0 cm
<b>G</b> : 9.8 x 29.0 cm	<b>O</b> : 19.5 x 19.5 cm	<b>W</b> : 29.0 x 40.0 cm
<b>H</b> : 14.5 x 19.5 cm	<b>P</b> : 25.0 x 34.5 cm	

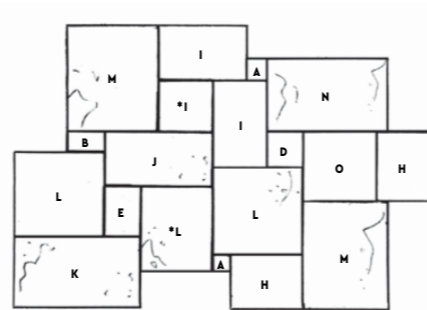

\* Has been trimmed

## DS-03

Flat Stone:  
Coverage (Per Box) : **6.8 ~ 7.2 sqf**  
Weight (Per Box) : **30.5 kg**  
Pieces (Per Box) : **19 ~ 23 pcs**

Corner Stone:  
Coverage (Per Box) : **4.9 ~ 5.1 f**  
Weight (Per Box) : **17.5 kg**  
Pieces (Per Box) : **8 pcs**

### Recommended Installation Layout

- Arrange stones randomly.
- Stones may be trimmed to fit the required size.  
(you may try laying the stones on the floor first).

\* Please allow a +/- 5% tolerance for stone size & colour  
\* This product may take longer to deliver, please contact us to find out more.

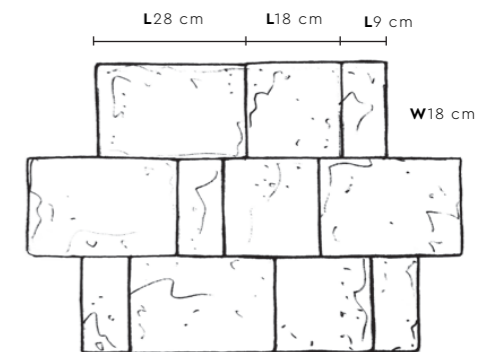



DS-021



DS-601



DS-605



DS-607



DS-024



DS-608



DS-609

## DS-021

Flat Stone:  
 Coverage (Per Box) : **6.2 ~ 6.5 sqf**  
 Weight (Per Box) : **26.7 kg**  
 Pieces (Per Box) : **17 ~ 21 pcs**

Corner Stone:  
 Coverage (Per Box) : **5.1 ~ 5.3 f**  
 Weight (Per Box) : **26.1 kg**  
 Pieces (Per Box) : **16 ~ 18 pcs**



## DS-024

Flat Stone:  
 Coverage (Per Box) : **5.8 ~ 6.2 sqf**  
 Weight (Per Box) : **29.2 kg**  
 Pieces (Per Box) : **20 ~ 24 pcs**

Corner Stone:  
 Coverage (Per Box) : **4.8 ~ 5.1 f**  
 Weight (Per Box) : **31.7 kg**  
 Pieces (Per Box) : **16 ~ 18 pcs**

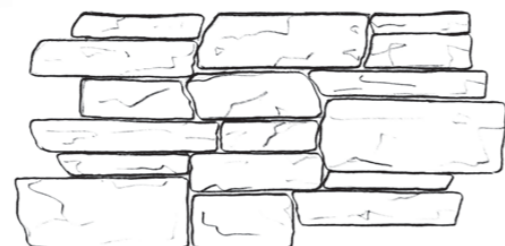

### Recommended Installation Layout

- Arrange stones randomly.
- Stones may be trimmed to fit the required size. (you may try laying the stones on the floor first).

\* Please allow a +/- 5% tolerance for stone size & colour.  
 \* This product may take longer to deliver, please contact us to find out more.

## DS-60

Coverage (Per Box) : **6.1 ~ 6.5 sqf**  
 Weight (Per Box) : **25.8 kg**  
 Pieces (Per Box) : **12 pcs**

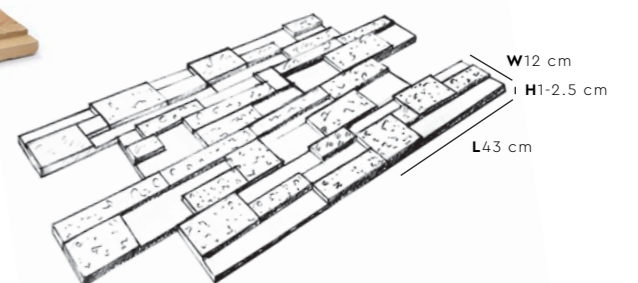

### Recommended Installation Layout

- Arrange the stones in a zig zag pattern.
- Arrange the colors/shades randomly and evenly (you may try laying the stones on the floor first).

\* Please allow a +/- 5% tolerance for stone size & colour.  
 \* This product may take longer to deliver, please contact us to find out more.



DS-111



DS-114



DS-116

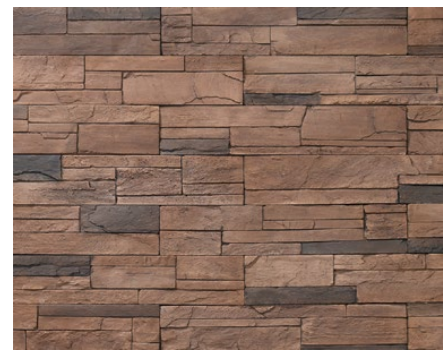

DS-117

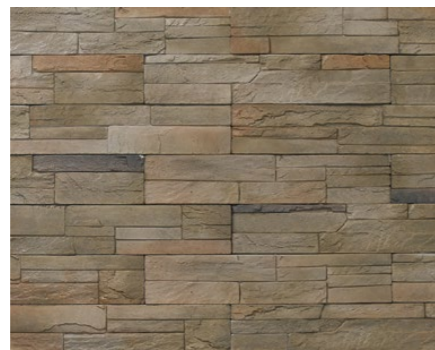

DS-118

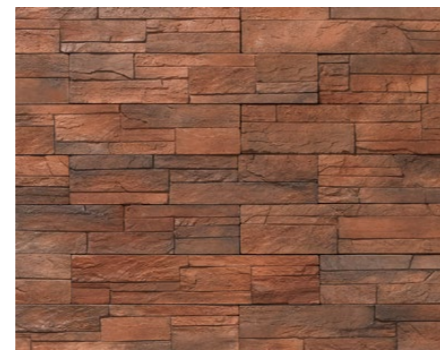

DS-119



PS-2001



PS-2002



PS-2004



PS-2005



PS-2006

## DS-11

Coverage (Per Box) : **10.5 ~ 10.8 sqf**  
 Weight (Per Box) : **30.3 kg**  
 Pieces (Per Box) : **20 pcs**

### Recommended Installation Layout

- Arrange the stones in a zig zag pattern.
- Arrange the colors/shades randomly and evenly (you may try laying the stones on the floor first).

\* Please allow a +/- 5% tolerance for stone size & colour.

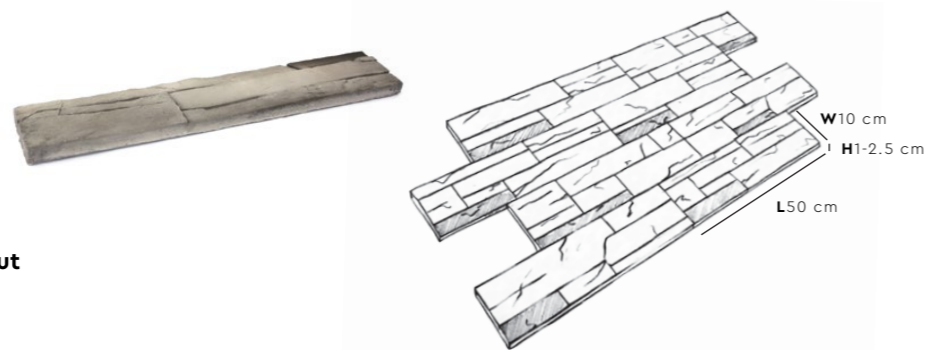

## PS-200

Coverage (Per Box) : **9.4 ~ 9.8 sqf**  
 Weight (Per Box) : **37.7 kg**  
 Pieces (Per Box) : **12 pcs**

### Recommended Installation Layout

- Arrange the stones in a zig zag pattern.
- Arrange the colors/shades randomly and evenly (you may try laying the stones on the floor first).

\* Please allow a +/- 5% tolerance for stone size & colour

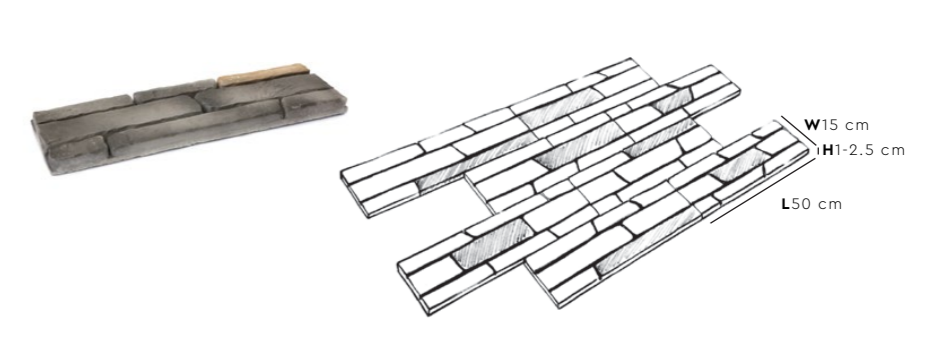



DS-091



DS-093



DS-094

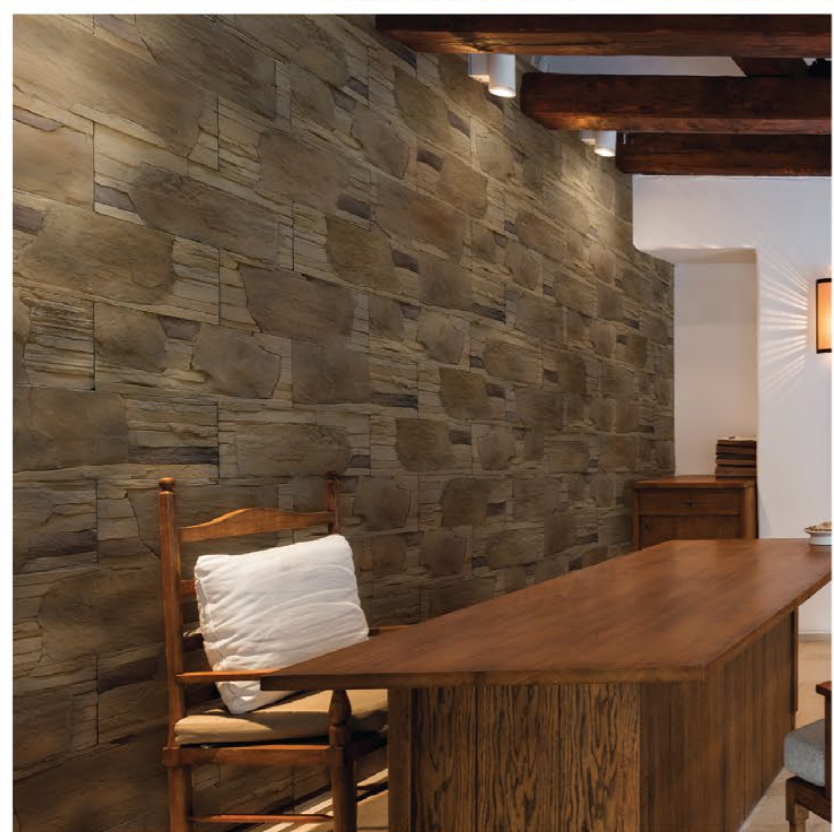

DS-701



DS-702



DS-703

## DS-09

Flat Stone:

Coverage (Per Box) : **5.9 ~ 6.2 sqf**

Weight (Per Box) : **27.7 kg**

Pieces (Per Box) : **10 ~ 15 pcs**

Corner Stone:

**5.1 ~ 5.3 f**

**29.8 kg**

**12 pcs**



- \* Please allow a +/- 5% tolerance for stone size and colour
- \* The packing coverage and length for DS-09XX are inclusive of 1cm groove lines
- \* This product may take longer to deliver, please contact us to find out more.

### Recommended Installation Layout

- Arrange stones randomly.
- Stones may be cut to fit the required size.  
(you may try laying the stones on the floor first).

### SIZES

**A** : 8.50 x 8.50cm

**B** : 8.50 x 18.0cm

**C** : 8.50 x 28.0cm

**D** : 8.50 x 38.0cm

**E** : 28.0 x 28.0cm

**F** : 28.0 x 18.5cm

**G** : 38.0 x 18.5cm

**H** : 38.0 x 28.0cm

**I** : 18.5 x 18.5cm

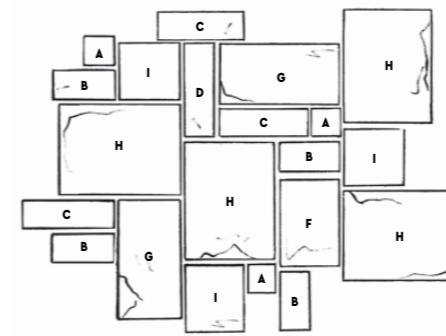

## DS-08

Flat Stone:

Coverage (Per Box) : **6.2 ~ 6.6 sqf**

Weight (Per Box) : **28.6 kg**

Pieces (Per Box) : **20 ~ 24 pcs**

Corner Stone:

**4.9 ~ 5.1 f**

**27.5 kg**

**15 pcs**

### Recommended Installation Layout

- Arrange stones randomly.
- Stones may be cut to fit the required size.  
(you may try laying the stones on the floor first).

- \* Please allow a +/- 5% tolerance for stone size & colour.
- \* This product may take longer to deliver, please contact us to find out more.



DS-081

## DS-70

Flat Stone:

Coverage (Per Box) : **10.2 ~ 11.0 sqf**

Weight (Per Box) : **43.8 kg**

Pieces (Per Box) : **12 pcs**

Corner Stone:

**8.3 ~ 8.7 f**

**33.1 kg**

**14 pcs**

- \* Please allow a +/- 5% tolerance for stone size and colour
- \* This product may take longer to deliver, please contact us to find out more.

### Recommended Installation Layout

- Arrange the stones in a zig zag pattern.
- Arrange the colors/shades randomly and evenly (you may try laying the stones on the floor first).

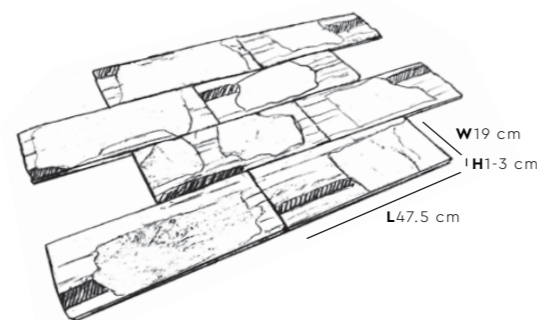

# KASTONE® CORNER PIECE & Accessories



AS-5201 (L) (44cm x 12cm x 5.5cm)



AS-5201 (M) (44cm x 12cm x 5.5cm)



AS-5201 (R) (44cm x 12cm x 5.5cm)

# KASTONE® GROUTING

## NEW IMPROVED FORMULA:

By protecting against water damage, more resistant to staining, discoloration & deterioration over time.



Coloured, cementitious and sand-based grouting, used to fill and support the joints between stones and bricks during installation. Formulated with coarse silica sand, synthetic resin, colour pigments, and water retentive additives, this durable material is applicable on any dry surface with widths between **4-15 mm**.



- Features:
- High Durability
  - Water Repellent
  - Stain & Mould Resistance
  - Water Resistant
  - Anti-chalking
  - Easy Application
  - Versatile Colours

Coverage:

Model Code	Coverage (sqf/kg)	Depth (mm)	Width (mm)
DS-02	1.5 ~ 1.7 sqf/kg	0.6 ~ 0.8 cm	Random
DS-07	1.4 ~ 1.6 sqf/kg	0.6 ~ 0.8 cm	Random
DS-08	1.5 ~ 1.7 sqf/kg	0.9 ~ 1.1 cm	Random
DS-04/09	1.8 ~ 2.0 sqf/kg	0.8 ~ 1.0 cm	1 cm

Packing Size:

Weight	Packing
3.5 kg / pack	4 packs / box
1.0 kg / pack	14 packs / box



# SUZUKA® STONE CARE

Topcoat for stone & other masonry surfaces for extra protection and durability.



- **High Gloss Finish:**  
An acrylic solvent-based topcoat allowing colour-enhancement and a glossy finish.

Coverage & Packing:

High Gloss		
1L	4L	18L
75 ~ 108sqf	301 ~ 431sqf	1,356 ~ 1,938sqf

- **Natural Finish:**  
An environmentally-friendly water-based topcoat that maintains the original color.

Coverage & Packing:

Natural		
1L	5L	18L
75 ~ 108sqf	377 ~ 538sqf	1,356 ~ 1,938sqf

Suitable for:

- SUZUKA® KASTONE® & Trowel Stone
- Stone / Brick Veneer
- Natural Stone
- Pebble Wash
- Concrete Imprint
- Bricks

\* Not recommended for pre-sealed surfaces or non-porous surfaces, such as ceramic tile, marble, granite, porcelain and terrazzo.

Features

- Easy Application
- UV Resistance
- High Adhesion
- Water, Algae & Fungus Resistance
- Long Lasting & High Endurance
- Stain Resistance & Easy Cleaning

# SUZUKA® WALL SEALER PRO

“ Make your wall finishes last longer! ”



Packing Size: **1L** **5L** **20L**

## Superior primer for concrete, skimmed or masonry surfaces.

This sealer that has good substrate penetration abilities to increase adhesion of product to prevent chalking or peeling off.

It has excellent alkaline resistance properties that can prevent efflorescence. It is an ideal base coat for any SUZUKA® or any wall finish products.

Coverage	Drying Time (hour)	
<b>6.5 - 8.5</b> m <sup>2</sup> /l/coat	Surface Dry : <b>1</b>	Substrate Temperature:
	Hard Dry : <b>5</b>	<b>23°C - 26°C</b>
	Recoating : <b>5</b>	

Features:

- Excellent alkaline resistance to prevent efflorescence.
- Good for new walls and repainting.
- Prevents skim coat from chalking & peeling off.
- Extremely good penetration.
- Excellent adhesion.
- Exterior and interior use.
- Applicable with brush, roller or spray gun.

Suitable for:

- Masonry wall
- Brickwork
- Plaster
- Skimmed Coat
- Asbestos free substrate

Airless Spray		
Nozzle	Spray Angle Degree	Pressure
<b>1.8 - 2.0 mm</b>	<b>65° - 80°</b>	<b>210 psi/150kg/cm<sup>2</sup></b>



# Installation Instructions



## Step 1 – Surface Preparation

- A Hack uniformly across the wall (using an axe, drill, or hammer) to create a rough and pitted texture on the surface.
- B Clean the surface to ensure it is free from dirt and dust.



## Step 2 – Mortar Application

Apply a generous layer of mortar across the wall using the notched edge trowel, creating a "combed" surface pattern.



## Step 3 – Stone Application

Complete this step starting from the bottom of the wall & moving upwards: Apply a thick layer of mortar onto the back side of a stone. Press the stone firmly onto the mortared wall surface, holding for a few seconds. Use spacers if necessary to ensure a level arrangement.

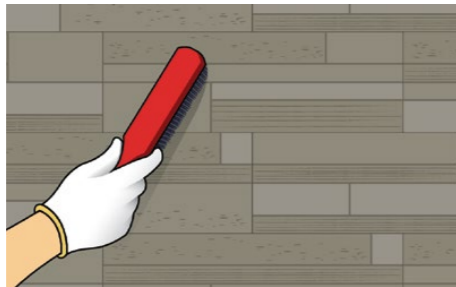

## Step 4 – Cleaning Up

Once the stones are firmly affixed, clean the surface with a dry brush to clear the stones of any dust.



## Step 5 – Topcoat Application (Optional)

It is recommended to apply a topcoat of either SUZUKA® High Gloss or SUZUKA® Natural Stone Care. This helps enhance the protection of SUZUKA® Stone Veneer against dirt, oil, grease, water stains, fungus, mold and weather conditions.

## Tools



# TECHNICAL SPECIFICATIONS

Series	Dimensions (cm)	Coverage /box (sqf)	Weight /box (kg)	Pieces /box	FLAT BRICK		CORNER BRICK		Boxes/Pallet (Flat/Corner)	m³/Pallet (Flat/Corner)
					Dimensions (cm)	Coverage /box (sqf)	Weight /box (kg)	Pieces /box		
DS-19	W28.5 x L48.5 x H7	3.7 ~ 4.2	30	3	-	-	-	-	30 / -	1.28 / -
DS-17	Random	5.9 ~ 6.3	20.6	24 ~ 27	-	-	-	-	24 / -	1.00 / -
KST-100	W20 x L60	7.6 ~ 7.8	20.2	6	-	-	-	-	48 / -	1.14 / -
PS-200	W15 x L50	9.4 ~ 9.8	37.7	12	-	-	-	-	24 / -	1.34 / -
DS-11	W10 x L50	10.5 ~ 10.8	30.3	20	-	-	-	-	32 / -	0.9 / -
DS-00	W10 x L20, 30, 50	6.9 ~ 7.6	26.8	14	W10 x S6 x L15, 25	5.1 ~ 5.3	15.4	16	32 / 32	1.12 / 1.12
DS-01	W10 x L20, 30, 50	5.9 ~ 6.5	23.2	12	W10 x S6 x L15, 25	5.1 ~ 5.3	15.5	16	32 / 32	1.12 / 1.12
DS-40	W10 x L20, 30, 50	6.9 ~ 7.6	26.8	14	W10 x S6 x L15, 25	5.1 ~ 5.3	15.4	16	32 / 32	1.12 / 1.12
DS-021	Random	6.2 ~ 6.5	26.7	17 ~ 21	Random	5.1 ~ 5.3	26.1	16 ~ 18	24 / 20	1.10 / 1.10
DS-024	Random	5.8 ~ 6.2	29.2	20 ~ 24	Random	4.8 ~ 5.1	31.7	16 ~ 18	20 / 20	1.28 / 1.28
DS-30	W12 x L40	7.2 ~ 7.8	30.5	16	W12 x S10 x L20	6.1 ~ 6.3	23.3	16	24 / 24	1.28 / 1.28
DS-70	W19 x L47.5	10.2 ~ 11.0	43.8	12	W19 x S6 x L16	8.3 ~ 8.7	33.1	14	24 / 24	1.15 / 1.15
DS-03	W18 x L9, 18, 28	6.8 ~ 7.2	30.5	19 ~ 23	W18 x S6 x L16, 25	4.9 ~ 5.1	17.5	8	32 / 32	1.12 / 1.12
DS-04	Random	7.0 ~ 7.4	29.6	17 ~ 21	Random	5.9 ~ 6.1	20.6	8	24 / 24	1.12 / 1.12
DS-07	Random	5.9 ~ 6.3	23.5	12 ~ 14	Random	5.9 ~ 6.1	27.8	7 ~ 8	24 / 20	1.10 / 1.28
DS-08	Random	6.2 ~ 6.6	28.6	20 ~ 24	Random	4.9 ~ 5.1	27.5	15	24 / 20	1.11 / 1.28
DS-09	Random	5.9 ~ 6.2	27.7	10 ~ 15	Random	5.1 ~ 5.3	29.8	12	24 / 20	1.11 / 1.28
DS-80	Random	10.5 ~ 10.8	33.4	35	Random	7.5 ~ 7.8	28.6	40	24 / 24	1.34 / 1.34
DS-60	W12 x L43	6.1 ~ 6.5	25.8	12	-	-	-	-	48 / -	1.25 / -
WS-300	W12 x L60	10.5 ~ 10.7	23.5	14	-	-	-	-	36 / -	1.10 / -
AS-520	W12 x L44	4.3 ~ 4.5	3.5/pc	12	-	-	-	-	- / -	- / -

\*Please allow a +/- 5% tolerance for stone size & colour. \*May vary in colour due to lighting conditions & printing. Please examine product samples before ordering.

## Calculation of Wall Coverage:

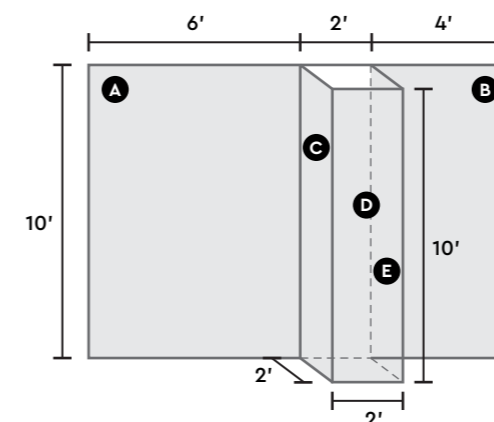

### Surface Dimension:

- A = 10' x 6' = 60 sqf
- B = 10' x 4' = 40 sqf
- C = 10' x 2' = 20 sqf
- D = 10' x 2' = 20 sqf
- E = 10' x 2' = 20 sqf
- Total = 160 sqf**

### Example for DS-04 Series:

- Flat = 160sqf - 2(10') (height of corners) = 140sqf / 7.4' (coverage per box) = **19 boxes** (estimate total box)
- Corner = 2(10') / 6.1 (coverage per box) = **4 boxes** (estimate total box)

